



### Construction

Self-draining, single-impeller pumps, with motor insulated from pumped water, constructed with high quality, corrosion-proof plastic materials, with stainless steel diffuser. Compact design (158 mm wide).

#### PVC pipe connections:

Ports for cementing joint, with external thread for union coupling.

### Applications

For spas, hydromassage bathtubs and whirlpool baths.

### Operating conditions

Water temperature up to 60 °C.

Room temperature up to 40 °C.

Maximum permissible pressure in the pump casing: 2,5 bar.

Continuous duty.

### Motor

2-pole induction motor, 50 Hz (n = 2800 rpm).

**SPA:** three-phase 230/400 V ± 10%.

**SPAM:** single-phase 230 V ± 10%, with thermal protector. Capacitor inside the terminal box.

Insulation class F.

Protection IP X5.

Constructed in accordance with: EN 60034-1;

EN 60335-1, EN 60335-2-41.

**Patents:** EP 0 460 597  
US 5 226 790

### Certification marks for SPAM



### Materials

Component	Material
Pump casing Union coupling	ABS (Acrylonitrile-Butadiene-Styrene)
Diffuser cover Impeller	Glass reinforced thermoplastic: PPO-GF30, NORYL*
Diffuser-wall with wear-ring	Cr-Ni-Mo stainless steel 1.4401 EN 10088 (AISI 316)
Mechanical seal	Ceramic alumina, Carbon, FPM

\* Trademark of General Electric

### Coverage chart n ≈ 2800 rpm

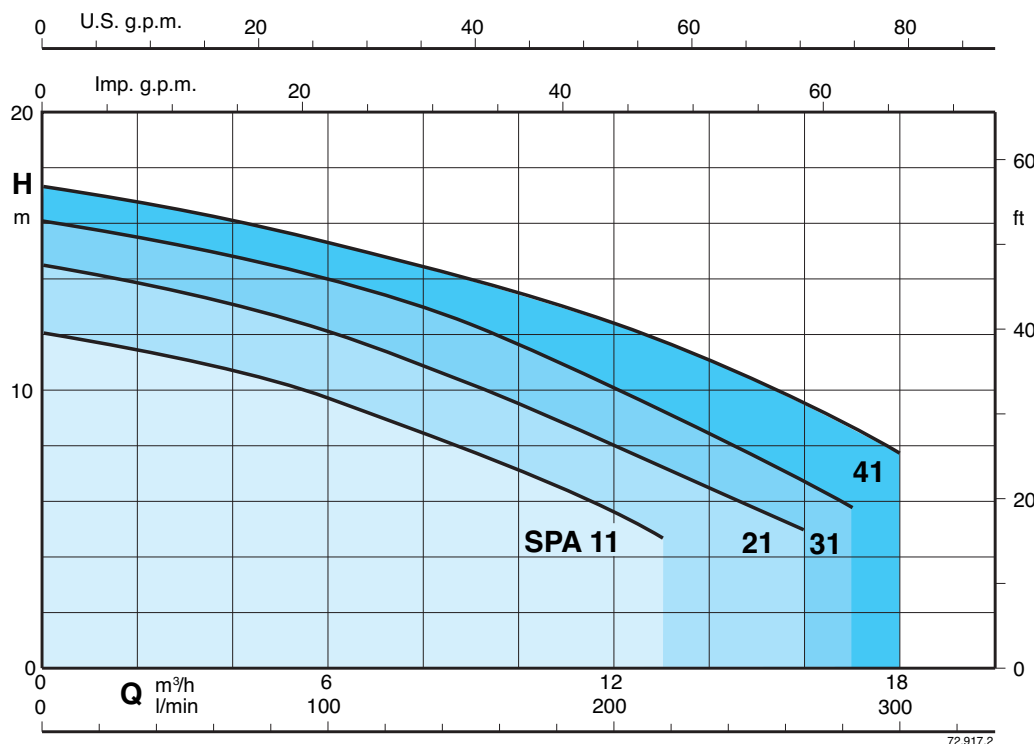

72.917.2

**Performance n ≈ 2800 rpm**

	3~		1~	230 V		P <sub>2</sub>		Q										
	230 V	400 V		230 V	P <sub>1</sub>	kW	HP		m <sup>3</sup> /h	0	3	6	9	12	13	16	17	18
	A	A	A	kW	kW	HP		l/min	0	50	100	150	200	216	266	283	300	
<b>SPA 11</b>	2,8	1,6	<b>SPAM 11</b>	0,73	0,45	0,6		12	11,1	9,7	7,8	5,6	4,7					
<b>SPA 21/A</b>	3	1,7	<b>SPAM 21/A</b>	1	0,55	0,75		14,5	13,4	12,1	10,2	7,9	7,2	5				
<b>SPA 31/A</b>	3,7	2,2	<b>SPAM 31/A</b>	1,2	0,75	1		16,1	15,2	13,9	12,4	10,2	9,3	6,8	5,8			
<b>SPA 41</b>	5	2,9	<b>SPAM 41</b>	1,6	1,1	1,5		17,3	16,5	15,3	14	12,4	11,8	9,5	8,6	7,7		

P<sub>1</sub> Max. power input.

P<sub>2</sub> Rated motor power output.

H Total head in m.

Tolerances according to ISO 9906, annex A.

**Dimensions and weights**

TYPE	mm							kg	
	f	L	h3	m1	m2	m3	w	SPA	SPAM
<b>SPA 11</b>	339	148	176	34	26	122	167	6,7	6,8
<b>SPA 21/A</b>	371	167	191	39	31	136	172	8	9
<b>SPA 31/A</b>	371	167	191	39	31	136	172	9	10

**SPA 11, 21/A, 31/A**

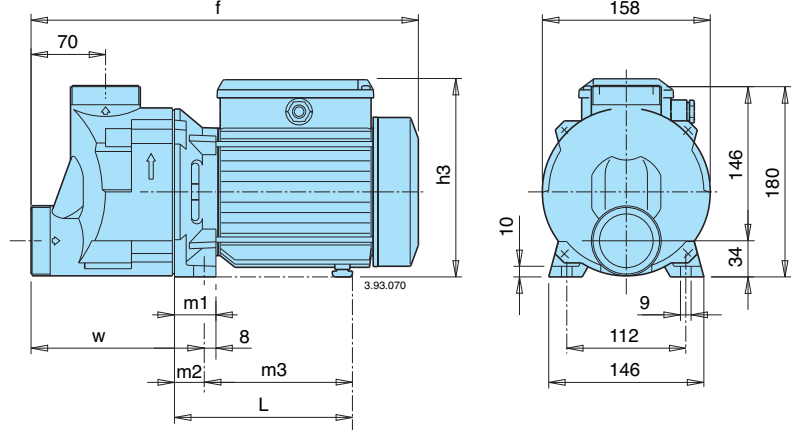

**SPA 41**

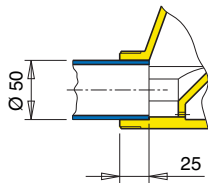
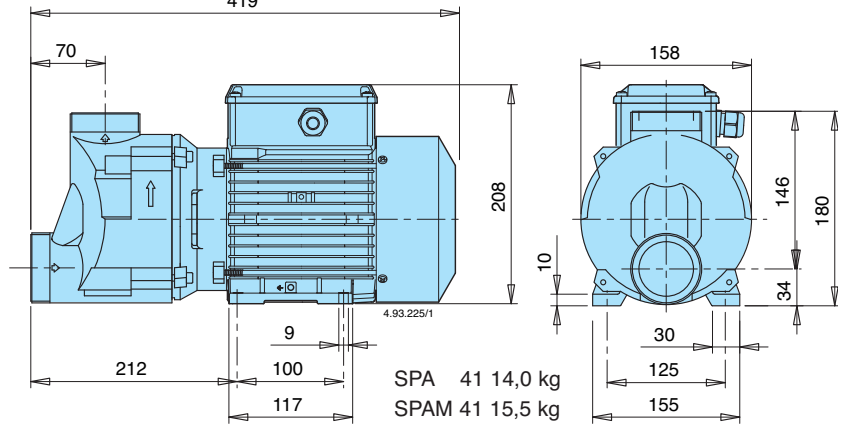

Cemented joint.

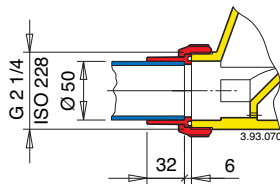

Threaded union coupling.

**Features**

Diffuser with peripheral-longitudinal flow, of stainless steel for **extra reliability**.

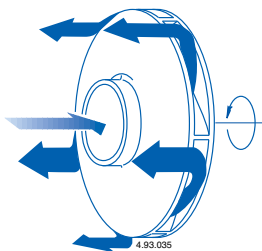

Mechanical seal without contact with the shaft, for **extra safety**.

