

CT 60

Peripheral Pump



Construction

Close-coupled peripheral pump (regenerative pump) with turbine impeller.

Compact, patented construction with single-piece motor casing and pump-side wall.

Protected against water entering the motor from outside.

Applications

For clean liquids without abrasives, without suspended solids, non-explosive, non-aggressive for the pump materials.

For increasing network pressure (follow local specifications).

For the reduced dimensions, these pumps are very well suitable to be mounted in cooling and air-conditioning machines and equipments, circulation.

Operating conditions

Liquid temperature up to 60 °C.

Ambient temperature up to 40 °C.

Total suction lift up to 7 m.

Continuous duty.

Motor

2-pole induction motor, 50 Hz ($n \approx 2900$ rpm).

CT 60: three-phase 230/400 V $\pm 10\%$.

CTM 60: single-phase 230 V $\pm 10\%$, with thermal protector. Capacitor inside the terminal box.

Insulation class F.

Protection IP 54.

Constructed in accordance with: EN 60034-1;

EN 60335-1, EN 60335-2-41.

Materials

Components	Materials
Pump casing	Cast iron GJL 200 EN 1561
Casing cover motor side	Brass P- Cu Zn Pb 2 UNI 5705
Impeller	Brass P- Cu Zn Pb 2 UNI 5705
Shaft	Chrome steel 1.4104 EN 10088 (AISI 430)
Mechanical seal	Carbon - Ceramic - NBR

Special features on request

- Other voltages.
- Frequency 60 Hz (as per 60 Hz data sheet).
- Special mechanical seal.

Coverage chart $n \approx 2900$ rpm

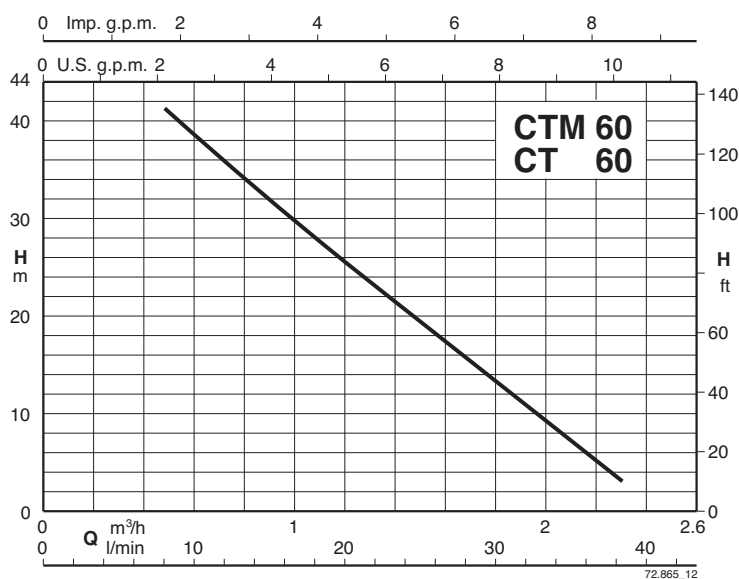

CT 60

Peripheral Pump



Performance $n \approx 2900$ rpm

3~	230V 400V		1~	230V	P ₁	P ₂		Q								
	A	A				A	kW		kW	HP	m ³ /h	0,48	0,6	0,75	0,96	1,2
CT 60/A	1,9	1,1	CTM 60/A	2,5	0,55	0,33	0,45	H m	41	38,5	35,5	31	25,5	19	11	3

H Total head in m.

P₂ Rated motor power output.

Dimensions and weights

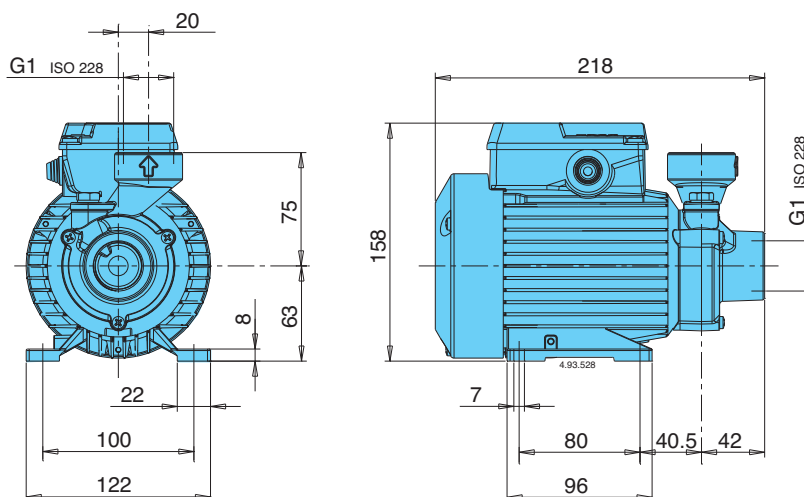

CT 60/A 4,9 kg
CTM 60/A 5 kg

Features

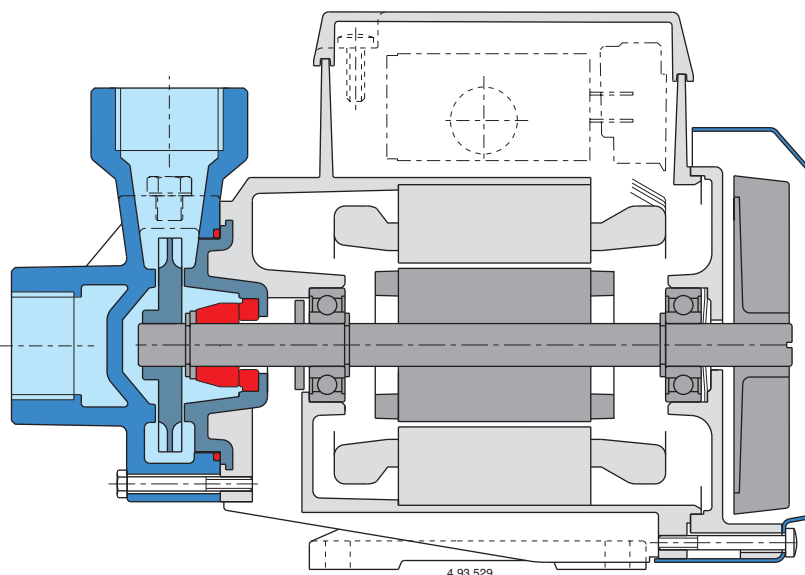

Patented